



Sawblades

TECHNISCHE INFORMATIONEN
 DATOS TECHNICOS
 INFORMAZIONE TECNICHE
 INFORMATION TECHNIQUES

Against feed (Power Cutting)



With feed – Automatic feed only

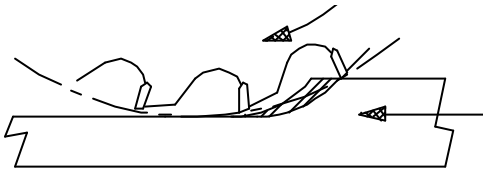

Circular Sawblades

TCT Sawblades are Tungsten Carbide tipped tools with centre bore. Tungsten Carbide teeth are brazed on to a high-density steel plate around the periphery.

Cutting Methods

Against feed (Power cutting)

This is the most commonly used cutting method for circular sawblades. Teeth cut against the direction of feed producing a long wedge chip. This method gives extended life and tool performance and is most effective when cutting a good quality grain.

Only cut against feed when hand feeding.

With feed

Teeth cut with the direction of feed immediately producing short chips on contact. This method allows high feed speed for less power and fine finishes can be achieved even on twisted grains.

Tooth life is reduced as the tooth rubs the timber following the cut. Automatic feed only.

Tooth Geometry

The tooth geometry of TCT circular sawblades varies accordingly to the application and type of material to be cut.

Index to tip angles.

- B Kerf width
- S Saw plate width
- a Clearance angle
- b Wedge angle
- y Hook angle
- aR Radial side angle
- n Side clearance angle
- l Bore axis angle

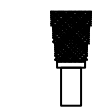
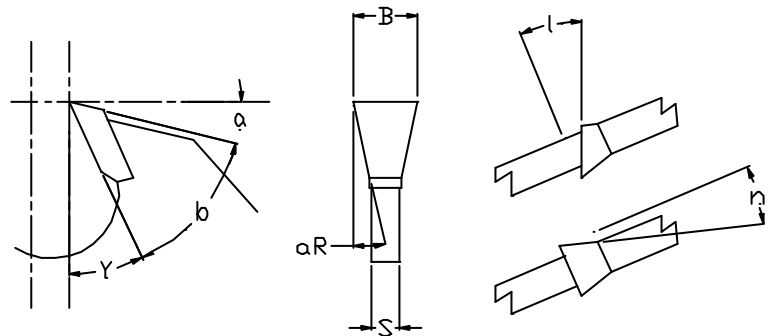

Flat tooth



Flat tooth - split



Flat bevel tooth

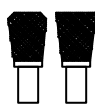

Triple chip tooth

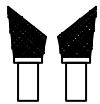

Alternating top bevel (ATB)

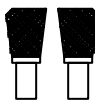

Flat ATB tooth



Conical tooth



RECOMMENDED TCT SAWBLADE USE

INDEX TO ICONS

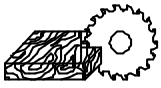

Soft / Hard exotic wood – across the grain

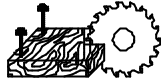

Soft / Hard exotic wood – with nails



Soft / Hard exotic wood – along the grain

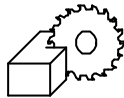

Autoclaved aerated concrete blocks

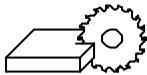

Particleboard - raw

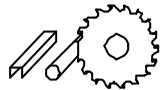

Soft / Hard exotic wood – along the grain

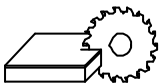

Particleboard – single face melamine



Plastics / Acrylics



Particleboard – double face melamine

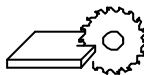

Alloyed / Unalloyed steel

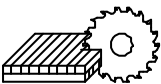

Blockboard



Compound / Sandwich panels / Mixed – recycled material

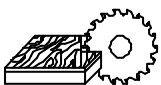

Particleboard – single face veneer

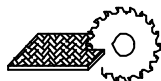

Veneers

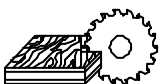

Particleboard – double face veneer

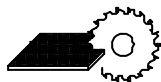

Printed Circuit Board (PCB's)

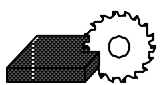

Cemented fibreboard



TECHNISCHE INFORMATIONEN
 DATOS TECHNICOS
 INFORMAZIONE TECNICHE
 INFORMATION TECHNIQUES

RATE OF FEED DIAGRAM

RECOMMENDED VALUES FOR RATE OF FEED PER TOOTH SZ

Lengthwise cut	0.2-0.8
Crosswise cut	0.1-0.2
Hardwood	0.05-0.15
Plywood	0.05-0.1
Particle boards	0.1-0.25
Plastics	0.02-0.06
Masonites	0.03-0.06

U Feed speed (m / min)
Z Number of teeth
SZ unit. Feed per tooth (mm)
n rpm

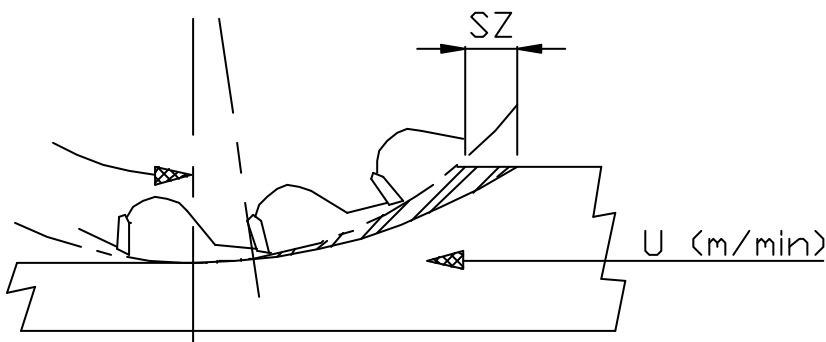

SZ

To obtain a more or less finished surface, it is necessary to set rate of feed to rpm and number of teeth to the finish SZ required.



TECHNISCHE INFORMATIONEN
 DATOS TECHNICOS
 INFORMAZIONE TECNICHE
 INFORMATION TECHNIQUES

RIM SPEED DIAGRAM

Relative to feed rate and tool diameter

RECOMMENDED RIM SPEEDS

Softwood	70-100 (ms ⁻¹)
Hardwood	70-90 (ms ⁻¹)
Particleboard	60-80 (ms ⁻¹)
Laminated boards	60-120 (ms ⁻¹)

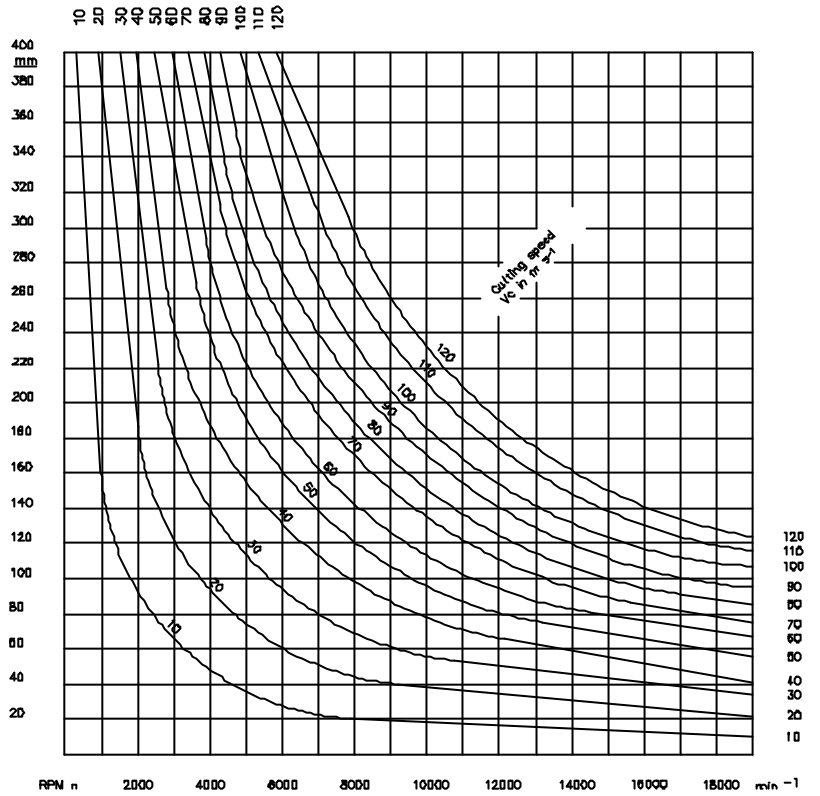

Rim Speed

Curves show rim speeds in meters per second, derived from rpm and tool diameter.

Rpm can be obtained from x-axis with known tool diameter and rim speed.



TECHNISCHE INFORMATIONEN
 DATOS TECHNICOS
 INFORMAZIONE TECNICHE
 INFORMATION TECHNIQUES

TC tooth regrind area.

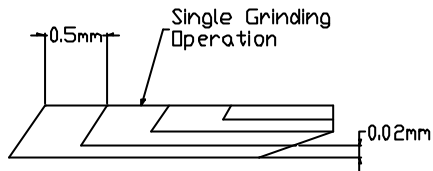

TCT Circular Sawblade Sharpening

Tooth geometry depends on material and application. TCT sawblade sharpening is done on manual and automatic sharpening machines as well as universal tool grinders. Sharpening required depends on the bluntness of the tool. It is advisable to regularly sharpen both tooth face and back to maintain a sharp cutting edge. The back usually wears more rapidly than the face. Sharpening on the face only reduces side clearance resulting in resin build up and material burning.

The ratio of grinding between tooth face and back is 0.05mm:0.2mm respectively.

When a tip is sharpened several times the backing plate must be reduced to prevent any possibility of the grinding wheel coming into contact with the sawbody.

All sawblades should be thoroughly cleaned before sharpening.

Automatic sharpening

When automatic sharpening refer to the grinding machine instructions for the grinding of circular sawblades. The correct cam is necessary relative to the tooth geometry. Automatic grinding allows the reduction of the saw plate behind the tip.

Machines should be set up to the correct blade thickness, cam and feed pawl relative to tooth pitch. When the sawblade is mounted on the center arbor the feed pawl should rest 2-3mm in front of the tooth face, within the top third of its length.

Machines can be set to grind on entering and leaving the tooth face or just on entering.

Manual sharpening

When exercised, manual sharpening is usually performed on a universal grinder to reduce tip and saw plate. It is recommended to initially sharpen the outside diameter to reset sawblade concentricity.

Guide to tables

D = Diameter

B = Kerf

b = Plate thickness

d = Bore size

Z = No. of teeth



RIP & CROSS CUT SAW BLADE ATB TOOTH

KREISSAGEBLATTER
HOJAS DE SIERRA CIRCULAIRES
LAME CIRCOLARI
LAMES DE SCIE CIRCULAIRES

03-006

Z – No. of teeth.

D (mm)	B	b	d	Z	Pinholes	Ref.
250	3.2	2.2	30	24	2 - 7x42	RCC25024ATB
250	3.2	2.2	30	30	2 - 7x42	RCC25030ATB
300	3.2	2.2	30	24	2 - 10x60	RCC30024ATB
300	3.2	2.2	30	28	2 - 10x60	RCC30028ATB
300	3.2	2.2	30	36	2 - 10x60	RCC30036ATB
315	3.2	2.2	30	28	2 - 7x42	RCC31528ATB
320	3.2	2.2	25	24	2 - 10x60	RCC32024ATB
335	3.2	2.2	30	36	2 - 10x60	RCC33536ATB
350	3.5	2.5	30	24	2 - 10x60	RCC35024ATB
350	3.5	2.5	30	32	2 - 10x60	RCC35032ATB
400	3.5	2.5	30	28	2 - 10x60	RCC40028ATB
400	3.5	2.5	25	32	2 - 10x60	RCC40032ATB
400	3.5	2.5	30	36	2 - 10x60	RCC40036ATB
400	3.5	2.5	30	48	2 - 10x60	RCC40048ATB
415	3.5	2.5	25	36		RCC41536ATB
450	3.8	2.8	30	40		RCC45040ATB
500	3.8	2.8	30	44		RCC50044ATB

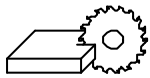
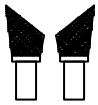
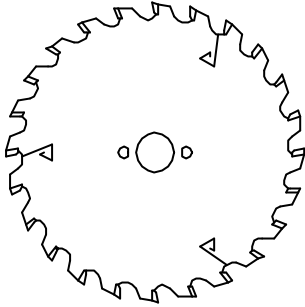

RIP SAW BLADE FLAT TOOTH

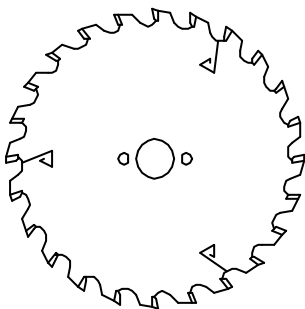

300	3.2	2.2	30	20	2 - 10x60	RIP30020FL
315	3.2	2.2	30	20	2 - 7x42	RIP31520FL
350	3.5	2.5	30	24	2 - 10x60	RIP35024FL
400	3.5	2.5	30	28	2 - 10x60	RIP40028FL
450	3.8	2.8	30	32		RIP45032FL
500	3.8	2.8	30	36		RIP50036FL

Other Bore sizes available on the whole range of sawblades



**MULTI RIP SAW BLADE
WIPERS - FLAT TOOTH**

KREISSAGEBLATTER
HOJAS DE SIERRA CIRCULAIRES
LAME CIRCOLARI
LAMES DE SCIE CIRCULAIRES

03-007

Z – No. of teeth.

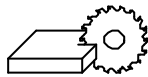
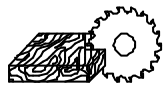
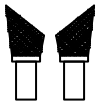
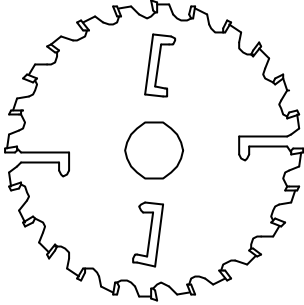

D (mm)	B	b	d	Z	Ref.
250	3	2.1	80	16+2	MR25016+2FL
250	3.4	2.2	80	16+2	MR25016+2FL
280	3.4	2.2	80	16+2	MR28016+2FL
280	3.8	2.5	80	16+2	MR28016+2FL
300	3.4	2.2	80	18+2	MR30018+2FL
300	3.4	2.2	70	20+4	MR30020+4FL
300	3.2	2.2	70	24+4	MR30024+4FL
320	3.4	2.2	70	20+4	MR30020+4FL
350	3.6	2.4	70	20+4	MR35020+4FL
350	4.2	2.8	70	20+4	MR35020+4FL



**RIP & CROSS CUT SAW BLADE
ATB TOOTH**

KREISSAGEBLATTER
HOJAS DE SIERRA CIRCULAIRES
LAME CIRCOLARI
LAMES DE SCIE CIRCULAIRES

03-008

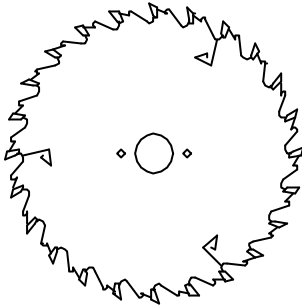
Z – No. of teeth.

D (mm)	B	b	d	Z	Pinholes	Ref.
250	3.2	2.2	30	24	2 - 7x42	RCC25024ATB
300	3.2	2.2	30	28	2 - 10x60	RCC30028ATB
315	3.2	2.2	30	28	2 - 7x42	RCC31528ATB
350	3.5	2.5	30	32	2 - 10x60	RCC35032ATB
400	3.5	2.5	30	36	2 - 10x60	RCC40036ATB
450	3.8	2.8	30	40		RCC45040ATB
500	3.8	2.8	30	44		RCC50044ATB
600	4.0	3.0	30	54		RCC60054ATB
700	4.2	3.2	30	60		RCC70060ATB

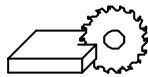
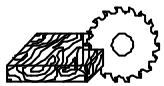
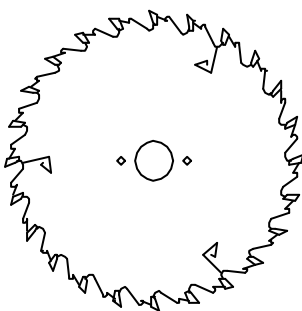
**RIP SAW BLADE
FLAT TOOTH**

250	3.2	2.2	30	24		RIP25024FL
300	3.2	2.2	30	28		RIP30028FL
350	3.5	2.5	30	32		RIP35032FL
400	3.5	2.5	30	36		RIP40036FL
450	3.8	2.8	30	40		RIP45040FL
500	3.8	2.8	30	44		RIP50044FL

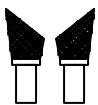

CONSTRUCTION SAW BLADE

KREISSAGEBLATTER
 HOJAS DE SIERRA CIRCULAIRES
 LAME CIRCOLARI
 LAMES DE SCIE CIRCULAIRES

Z – No. of teeth.

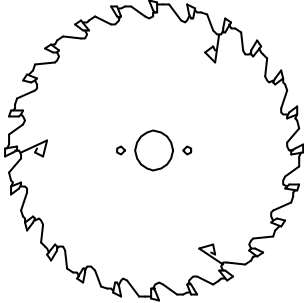

D (mm)	B	b	d	Z	Pinholes	Ref.
180	2.6	1.6	30	12		CON18012ATBF
190	2.8	1.8	30	12		CON19012ATBF
200	2.8	1.8	30	14		CON20014ATBF
210	2.8	1.8	30	14		CON21014ATBF
235	2.8	1.8	30	16		CON23516ATBF
240	2.8	1.8	30	16		CON24016ATBF
250	3.2	2.2	30	16	2 - 7x42	CON25016ATBF
280	3.2	2.2	30	18		CON28018ATBF
300	3.2	2.2	30	20	2 - 10x60	CON30020ATBF
315	3.2	2.2	30	20	2 - 7x42	CON31520ATBF
350	3.5	2.5	30	24	2 - 10x60	CON35024ATBF
400	3.5	2.5	30	28	2 - 10x60	CON40028ATBF
450	3.8	2.8	30	32		CON45032ATBF
500	3.8	2.8	30	36		CON50036ATBF
600	4.0	3.0	30	40		CON60040ATBF
700	4.2	3.2	30	46		CON70046ATBF

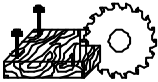
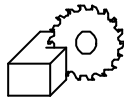
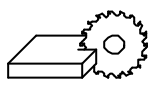
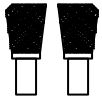

**CROSS CUT & TRIMMING
SAW BLADE – ATB TOOTH**

KREISSAGEBLATTER
HOJAS DE SIERRA CIRCULAIRES
LAME CIRCOLARI
LAMES DE SCIE CIRCULAIRES

03-010

Z – No. of teeth.

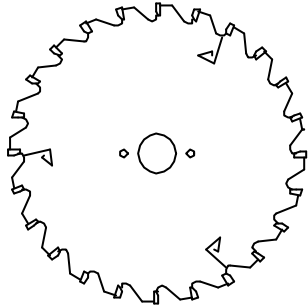

D (mm)	B	b	d	Z	Pinholes	Ref.
150	3.2	2.2	30	24		CCT15024ATB
150	3.2	2.2	30	36		CCT15036ATB
150	3.2	2.2	30	48		CCT15048ATB
180	3.2	2.2	30	30		CCT18030ATB
180	3.2	2.2	30	54		CCT18054ATB
200	3.2	2.2	30	34		CCT20034ATB
200	3.2	2.2	30	48		CCT20048ATB
200	3.2	2.2	30	64		CCT20064ATB
250	3.2	2.2	16	40		CCT25040ATB
250	3.2	2.2	20	40		CCT25040ATB
250	3.2	2.2	30	40	2 - 7x42	CCT25040ATB
250	3.2	2.2	30	48	2 - 7x42	CCT25048ATB
250	3.2	2.2	16	60		CCT25060ATB
250	3.2	2.2	30	60	2 - 7x42	CCT25060ATB
250	3.2	2.2	16	80		CCT25080ATB
250	3.2	2.2	30	80	2 - 7x42	CCT25080ATB

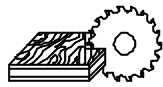
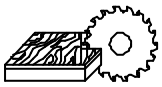
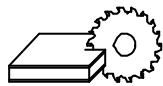
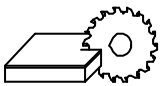
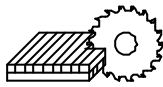
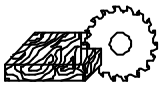
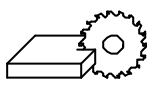
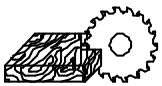
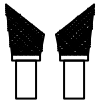

**CROSS CUT & TRIMMING
SAW BLADE – ATB TOOTH**

KREISSAGEBLATTER
HOJAS DE SIERRA CIRCULAIRES
LAME CIRCOLARI
LAMES DE SCIE CIRCULAIRES

03-011

Z – No. of teeth.

D (mm)	B	b	d	Z	Pinholes	Ref.
300	3.2	2.2	16	48		CCT30048ATB
300	3.2	2.2	30	48	2 - 10x60	CCT30048ATB
300	3.2	2.2	30	60	2 - 10x60	CCT30060ATB
300	3.2	2.2	16	72		CCT30072ATB
300	3.2	2.2	30	72	2 - 10x60	CCT30072ATB
300	3.2	2.2	16	96		CCT30096ATB
300	3.2	2.2	30	96	2 - 10x60	CCT30096ATB
300	3.2	2.2	30	120	2 - 10x60	CCT300120ATB
315	3.2	2.2	30	48		CCT31548ATB
315	3.2	2.2	30	60		CCT31560ATB
315	3.2	2.2	30	72		CCT31572ATB
320	3.2	2.2	25	48		CCT32048ATB
350	3.5	2.5	30	54	2 - 10x60	CCT35054ATB
350	3.5	2.5	30	72	2 - 10x60	CCT35072ATB
350	3.5	2.5	30	84	2 - 10x60	CCT35084ATB
350	3.5	2.5	30	108	2 - 10x60	CCT350108ATB
400	3.5	2.5	30	60	2 - 10x60	CCT40060ATB
400	3.5	2.5	30	84	2 - 10x60	CCT40084ATB
400	3.5	2.5	30	96	2 - 10x60	CCT40096ATB
400	3.5	2.5	30	120	2 - 10x60	CCT400120ATB
450	3.8	2.8	30	66		CCT45066ATB
450	3.8	2.8	30	108		CCT450108ATB
500	3.8	2.8	30	72		CCT50072ATB

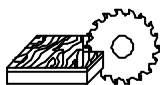
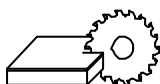
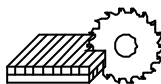
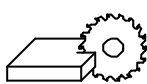
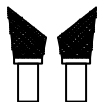
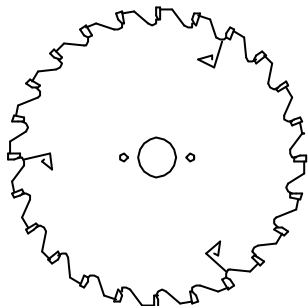

**CUT-OFF & MITER SAW BLADE
NEG**

KREISSAGEBLATTER
HOJAS DE SIERRA CIRCULAIRES
LAME CIRCOLARI
LAMES DE SCIE CIRCULAIRES

Z – No. of teeth.

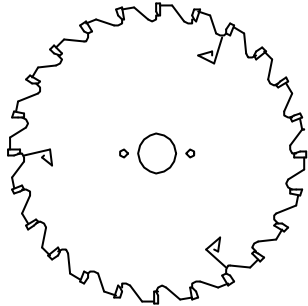

D (mm)	B	b	d	Z	Pinholes	Ref.
216	2.8	1.8	30	24		MIT21624*
216	2.8	1.8	30	48		MIT21648*
216	2.8	1.8	30	60		MIT21660*
250	3.2	2.2	30	40	2 - 7x42	MIT25040*
250	3.2	2.2	30	48	2 - 7x42	MIT25048*
250	3.2	2.2	30	60	2 - 7x42	MIT25060*
250	3.2	2.2	30	80	2 - 7x42	MIT25080*

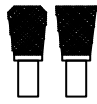
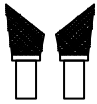

* Tooth type relevant to application.

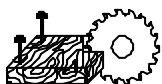
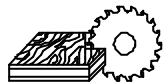
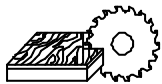
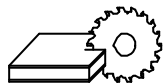
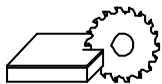
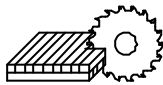
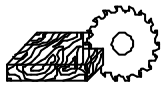
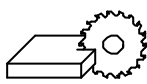
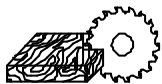

**GROOVING SAW BLADE
FLAT TOOTH**

KREISSAGEBLATTER
HOJAS DE SIERRA CIRCULAIRES
LAME CIRCOLARI
LAMES DE SCIE CIRCULAIRES

03-013

Z – No. of teeth.

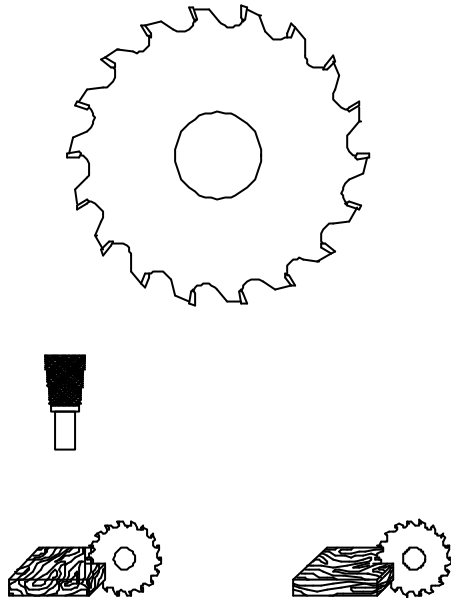

D (mm)	B	b	d	Z	Ref.
125	1.5	1.0	30	12	GRO12512FL01
125	1.8	1.0	30	12	GRO12512FL02
125	2.0	2.0	30	12	GRO12512FL03
125	2.2	2.0	30	12	GRO12512FL04
125	2.5	2.0	30	12	GRO12512FL05
125	3.0	2.0	30	12	GRO12512FL06
125	3.5	2.5	30	12	GRO12512FL07
125	4.0	3.0	30	12	GRO12512FL08
125	4.5	3.5	30	12	GRO12512FL09
125	5.0	4.0	30	12	GRO12512FL10
125	6.0	5.0	30	12	GRO12512FL11
125	1/4	5.0	30	12	GRO12512FL12
125	7.0	6.0	30	12	GRO12512FL13
125	8.0	6.0	30	12	GRO12512FL14
125	10.0	8.0	30	12	GRO12512FL15
150	1.5	1.0	30	12	GRO15012FL01
150	2.0	1.0	30	12	GRO15012FL02
150	2.2	2.0	30	12	GRO15012FL03
150	2.5	2.0	30	12	GRO15012FL04
150	3.0	2.0	30	12	GRO15012FL05
150	3.5	2.5	30	12	GRO15012FL06
150	4.0	3.0	30	12	GRO15012FL07
150	4.5	3.5	30	12	GRO15012FL08



**GROOVING SAW BLADE
FLAT TOOTH**

KREISSAGEBLATTER
HOJAS DE SIERRA CIRCULAIRES
LAME CIRCOLARI
LAMES DE SCIE CIRCULAIRES

03-014

Z – No. of teeth.

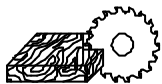
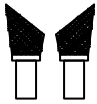
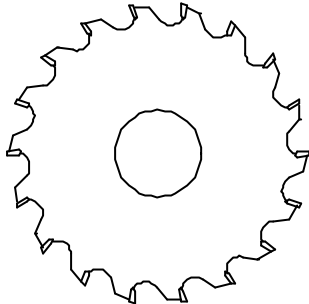

D (mm)	B	b	d	Z	Ref.
150	5.0	4.0	30	12	GRO15012FL01
150	6.0	5.0	30	12	GRO15012FL02
150	1/4	5.0	30	12	GRO15012FL03
150	7.0	6.0	30	12	GRO15012FL04
150	8.0	6.0	30	12	GRO15012FL05
150	10.0	8.0	30	12	GRO15012FL06
180	4.0	3.0	30	12	GRO18012FL01
180	5.0	4.0	30	12	GRO18012FL02
180	6.0	5.0	30	12	GRO18012FL03
180	8.0	6.0	30	12	GRO18012FL04
180	10.0	8.0	30	12	GRO18012FL05
150	1.5	1.0	30	18	GRO15018FL01
150	2.0	1.0	30	18	GRO15018FL02
150	2.5	2.0	30	18	GRO15018FL03
150	3.0	2.0	30	18	GRO15018FL04
150	3.5	2.5	30	18	GRO15018FL05
150	4.0	3.0	30	18	GRO15018FL06
150	4.5	3.5	30	18	GRO15018FL07
150	5.0	4.0	30	18	GRO15018FL08
150	6.0	5.0	30	18	GRO15018FL09
150	7.0	6.0	30	18	GRO15018FL10
150	8.0	6.0	30	18	GRO15018FL11
150	10.0	8.0	30	18	GRO15018FL12
180	4.0	3.0	30	18	GRO18018FL01
180	5.0	4.0	30	18	GRO18018FL02
180	6.0	5.0	30	18	GRO18018FL03
180	8.0	6.0	30	18	GRO18018FL04
180	10.0	8.0	30	18	GRO18018FL05



THIN KERF SAW BLADES ATB TOOTH

KREISSAGEBLATTER
HOJAS DE SIERRA CIRCULAIRES
LAME CIRCOLARI
LAMES DE SCIE CIRCULAIRES

Z – No. of teeth.

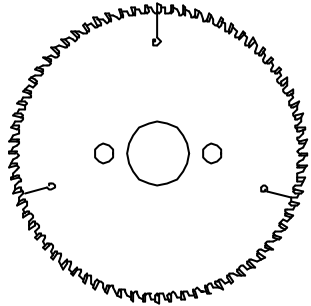

D (mm)	B	b	d	Z	Ref.
150	2.0	1.2	30	24	THK15024ATB
150	2.0	1.2	30	48	THK15048ATB
160	2.0	1.2	30	24	THK16024ATB
160	2.0	1.2	30	48	THK16048ATB
160	2.2	1.6	30	60	THK16060ATB
180	2.0	1.2	30	30	THK18030ATB
180	2.0	1.2	30	56	THK18056ATB
180	2.2	1.6	30	72	THK18072ATB
200	2.0	1.2	30	32	THK20032ATB
200	2.0	1.2	30	64	THK20064ATB
200	2.2	1.6	30	80	THK20080ATB
250	2.0	1.6	30	40	THK25040ATB
250	2.0	1.2	30	80	THK25080ATB
250	2.2	1.6	30	100	THK250100ATB

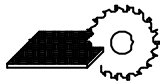
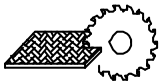
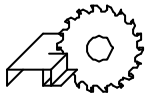
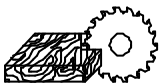
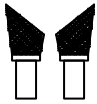

PANEL SIZING SAW BLADES

KREISSAGEBLATTER
HOJAS DE SIERRA CIRCULAIRES
LAME CIRCOLARI
LAMES DE SCIE CIRCULAIRES

03-016

Z – No. of teeth.

D (mm)	B	b	d	Z	Pinholes	Ref.
220	3.2	2.2	30	64	2 - 7x42	PAN22064TC
250	3.2	2.2	30	60		PAN25060TC
250	3.2	2.2	16	80		PAN25080TC01
250	3.2	2.2	30	80	2 - 7x42	PAN25080TC02
250	4.4	2.8	30	48		PAN25048TC
300	3.2	2.2	30	60		PAN30060TC
300	3.2	2.2	30	72	2 - 10x60	PAN30072TC
300	3.2	2.2	25	96		PAN30096TC01
300	3.2	2.2	30	96	2 - 10x60	PAN30096TC02
300	4.4	2.8	30	60	2 - 10x60	PAN30060TC
300	4.4	2.8	30	72	2 - 10x60	PAN30072TC
305	4.4	3.0	30	48		PAN30548TC
305	4.4	3.0	30	60		PAN30560TC01
305	4.4	3.0	60	60		PAN30560TC02
350	3.5	2.5	30	72	2 - 10x60	PAN35072TC
350	4.4	2.8	30	54	2 - 10x60	PAN35054TC
350	4.4	3.0	75	60		PAN35060TC
350	4.4	2.8	30	72	2 - 10x60	PAN35072TC01
350	4.4	3.0	30	72		PAN35072TC02
355	4.4	3.0	75	54		PAN35554TC
355	4.4	3.0	30	72		PAN35572TC01
355	4.4	3.0	75	72		PAN35572TC02
355	4.4	3.0	80	72		PAN35572TC03
380	4.4	3.5	60	72		PAN38072TC

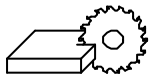
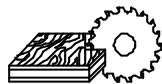
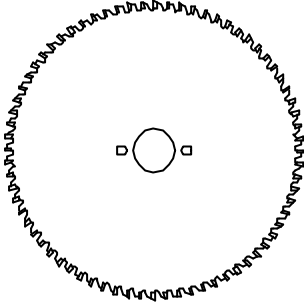

PANEL SIZING SAW BLADES

KREISSAGEBLATTER
HOJAS DE SIERRA CIRCULAIRES
LAME CIRCOLARI
LAMES DE SCIE CIRCULAIRES

03-017

Z – No. of teeth.

D (mm)	B	b	d	Z	Pinholes	Ref.
400	4.4	3.0	30	60		PAN40060TC
400	4.4	3.0	60	60		PAN40060TC
400	4.4	3.0	30	72		PAN40072TC
400	4.4	3.0	60	72		PAN40072TC
400	4.4	3.0	75	72	4 - 15x105	PAN40072TC
400	4.4	3.0	80	72	2 - 9x130	PAN40072TC
400	4.8	3.5	60	60		PAN40060TC
420	4.8	3.5	30	72		PAN42072TC
430	4.4	3.0	30	72		PAN43072TC
430	4.4	3.0	60	72	1 - 11x85	PAN43072TC
430	4.4	3.0	75	72	2 - 9x130	PAN43072TC
430	4.4	3.0	80	72	4 - 15x105	PAN43072TC
450	4.4	3.0	30	96		PAN45096TC
450	4.4	3.0	80	54		PAN45054TC
450	4.4	3.0	30	72		PAN45072TC01
450	4.4	3.0	80	72	2 - 9x130	PAN45072TC02
450	4.4	3.5	60	72		PAN45072TC03
500	4.4	3.0	30	60		PAN50060TC01
500	4.4	3.0	75	60		PAN50060TC02
500	4.4	3.0	80	60		PAN50060TC03
500	4.4	3.0	60	72		PAN50072TC01
500	4.4	3.0	80	72		PAN50072TC02
500	4.8	3.5	60	60		PAN50060TC04
500	4.8	3.5	60	72		PAN50072TC03
520	4.8	3.5	60	60		PAN52060TC01
520	4.8	3.5	60	72		PAN52072TC
520	5.8	4.0	60	60		PAN52060TC02
530	5.8	4.0	60	60		PAN53060TC
550	5.0	3.5	80	60		PAN55060TC
550	5.0	3.5	100	72		PAN55072TC
570	4.8	3.5	60	60		PAN57060TC01
570	5.8	4.0	60	60		PAN57060TC02
303	3.2	2.2	30	60		PAN30360TC

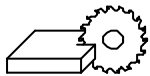
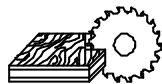
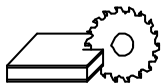
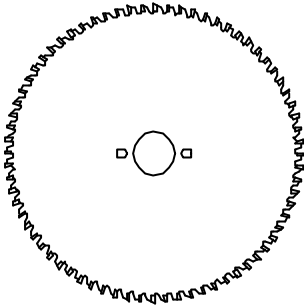

**SCORING SAW BLADES
SPLIT TOOTH**

KREISSAGEBLATTER
HOJAS DE SIERRA CIRCULAIRES
LAME CIRCOLARI
LAMES DE SCIE CIRCULAIRES

Z – No. of teeth.

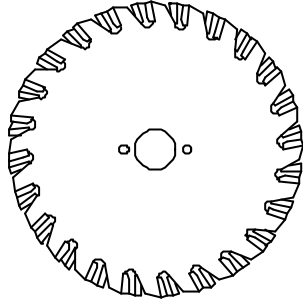

D(mm)	B	b	d	Z	Pinholes	Ref.
100	2.8-3.6	1.8	20	2x10		SCO100210SP01
100	2.8-3.6	1.8	22	2x10		SCO100210SP02
105	2.8-3.6	1.8	20	2x10		SCO105210SP
120	2.8-3.6	1.8	20	2x12		SCO120212SP01
120	2.8-3.6	1.8	22	2x12		SCO120212SP02

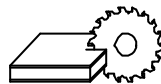
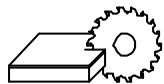
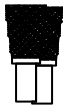

**SCORING SAW BLADES
CONICAL TOOTH**

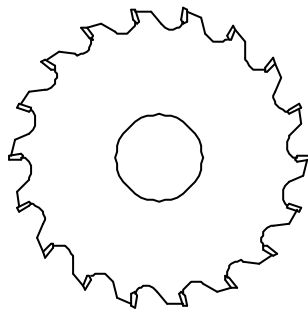

100	3.2-4.2	2.2	20	20		SCO10020CON
105	3.2-4.2	1.8	20	16		SCO10516CON
120	3.0-4.0	2.0	20	20		SCO12020CON
125	3.0-4.0	2.0	20	20		SCO12520CON01
125	4.4-5.6	3.4	20	20		SCO12520CON02
125	4.4-5.6	3.4	22	20		SCO12520CON03
125	4.4-5.6	3.4	45	20		SCO12520CON04
125	4.0-5.0	3.0	45	24		SCO12524CON01
125	4.2-5.0	3.2	45	20		SCO12520CON05
125	4.4-5.2	3.4	45	24		SCO12524CON02
140	3.2-4.2	2.2	16	32	2 - 7.5x31.5	SCO14032CON
150	4.4-5.6	3.4	20	24		SCO15024CON01
150	4.4-5.6	3.4	30	24		SCO15024CON02
160	4.4-5.6	3.4	45	28	3 - 11x70	SCO16028CON
160	4.4-5.6	3.4	55	36	3 - 6.5x66	SCO16036CON
175	4.8-5.8	3.8	45	28		SCO17528CON
180	3.2-4.2	2.2	16	42	2 - 7.5x31.5	SCO18042CON
180	4.4-5.6	3.4	20	30		SCO18030CON01
180	4.4-5.6	3.4	30	30		SCO18030CON02
200	3.1-4.1	2.1	30	60		SCO20060CON
200	4.4-5.6	3.4	30	36		SCO20036CON01
200	4.4-5.6	3.4	65	36	2 - 9x110	SCO20036CON02
200	4.8-5.8	3.8	45	36		SCO20036CON03

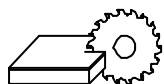

NON-FERROUS SAW BLADES TRIPLE CHIP TOOTH

KREISSAGEBLATTER
HOJAS DE SIERRA CIRCULAIRES
LAME CIRCOLARI
LAMES DE SCIE CIRCULAIRES

Z – No. of teeth.

D(mm)	B	b	d	Z	Pinholes	Ref.
250	3.2	2.6	30	60		NF25060TC01
250	3.2	2.6	32	60		NF25060TC02
250	3.2	2.6	30	80		NF25080TC
275	3.2	2.6	40	72	2 - 9x55	NF27572TC01
275	3.2	2.6	40	72	4 - 12x64	NF27572TC02
300	3.2	2.6	30	72		NF30072TC01
300	3.2	2.6	32	72		NF30072TC02
300	3.2	2.6	30	96		NF30096TC01
300	3.2	2.6	32	96		NF30096TC02
350	3.2	2.6	40	92	2 - 9x55	NF35092TC01
350	3.2	2.6	40	92	4 - 12x64	NF35092TC02
350	3.2	2.6	30	108		NF350108TC

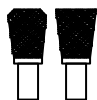
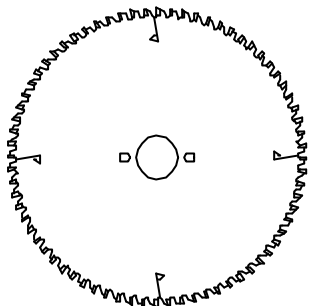

NON-FERROUS SAW BLADES TRIPLE CHIP TOOTH NEG

250	3.2	2.6	30	60		NF25060TCN01
250	3.2	2.6	32	60		NF25060TCN02
250	3.2	2.6	25	80		NF25080TCN01
250	3.2	2.6	30	80	2 - 7x42	NF25080TCN02
250	3.2	2.6	32	80		NF25080TCN03
250	3.2	2.6	40	80	2 - 9x55	NF20580TCN01
250	3.2	2.6	40	80	4 - 12x64	NF20580TCN02
275	3.2	2.6	40	88	2 - 9x55	NF27588TCN01
275	3.2	2.6	40	88	4 - 12x64	NF27588TCN02
300	3.2	2.6	30	72		NF30072TCN01
300	3.2	2.6	32	72		NF30072TCN02
300	3.2	2.6	30	96		NF30096TCN01
300	3.2	2.6	32	96		NF30096TCN02
330	3.2	2.6	20	96		NF33096TCN01
330	3.2	2.6	30	96		NF33096TCN02
330	3.2	2.6	32	96		NF33096TCN03
350	3.2	2.6	25	84		NF35084TCN01
350	3.2	3.2	40	84	2 - 9x55	NF35084TCN02
350	3.2	3.2	40	84	4 - 12x64	NF35084TCN03
350	3.2	2.6	30	90		NF35090TCN
350	3.2	2.6	30	108		NF350108TCN01
350	3.2	2.6	40	108	2 - 9x55	NF350108TCN02
350	3.2	2.6	40	108	4 - 12x64	NF350108TCN03

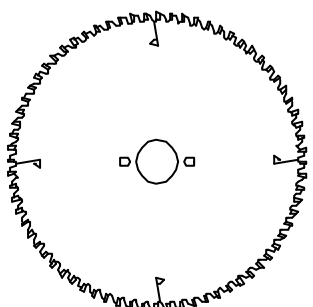

**PARAT SAW BLADES
UNIVERSAL MATERIAL CUTTING
TRIPLE CHIP TOOTH
NEG**

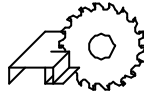
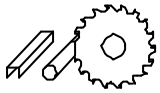
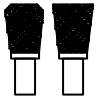
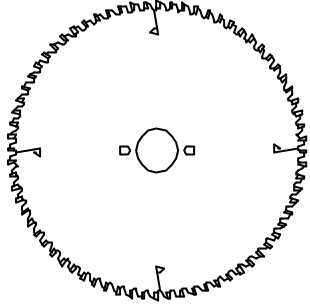

KREISSAGEBLATTER
HOJAS DE SIERRA CIRCULAIRES
LAME CIRCOLARI
LAMES DE SCIE CIRCULAIRES

03-020

Z – No. of teeth.

D(mm)	B	b	d	Z	Pinholes	Ref.
180	2.8	2.2	20	48		PAR18048TCN01
180	2.8	2.2	30	48		PAR18048TCN02
184	2.8	2.2	16	48		PAR18448TCN01
184	2.8	2.2	20	48		PAR18448TCN02
184	2.8	2.2	30	48		PAR18448TCN03
190	2.8	2.2	20	54		PAR19054TCN01
190	2.8	2.2	30	54		PAR19054TCN02
200	2.8	2.2	30	54		PAR20054TCN
210	2.8	2.2	30	54		PAR21054TCN
220	2.8	2.2	30	54		PAR22054TCN
230	2.8	2.2	30	64		PAR23064TCN
235	2.8	2.2	30	64		PAR23564TCN
240	2.8	2.2	30	64		PAR24064TCN
250	3.2	2.6	30	80	2 - 7x42	PAR25080TCN
260	3.2	2.6	30	72		PAR26072TCN
300	3.2	2.6	30	84	2 - 10x60	PAR30084TCN



KREISSAGEBLATTER
HOJAS DE SIERRA CIRCULAIRES
LAME CIRCOLARI
LAMES DE SCIE CIRCULAIRES

Z – No. of teeth.

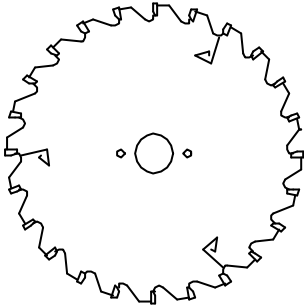

D (in)	d	Z	Ref.
5	5/8	14	PS514
6	5/8	20	PS620
6	5/8	30	PS630
6	5/8	40	PS640
6 1/4	5/8	20	PS61/420
6 1/4	5/8	30	PS61/430
6 1/4	5/8	40	PS61/440
7 1/4	5/8	20	PS71/420
7 1/4	5/8	30	PS71/430
7 1/4	5/8	40	PS71/440
7 1/4	5/8	60	PS71/460
7 1/2	5/8	20	PS71/220
7 1/2	5/8	30	PS71/230
7 1/2	5/8	40	PS71/240
7 1/2	5/8	60	PS71/260
8	5/8	20	PS820
8	5/8	30	PS830
8	5/8	40	PS840
8	5/8	60	PS860
8 1/4	5/8	20	PS81/420
8 1/4	5/8	30	PS81/430
8 1/4	5/8	40	PS81/440
8 1/4	5/8	60	PS81/460
9 1/4	30mm	20	PS91/43020
9 1/4	30mm	30	PS91/43030
9 1/4	30mm	40	PS91/43040
9 1/4	30mm	60	PS91/43060
10	5/8	20	PS1020
10	5/8	30	PS1030
10	5/8	40	PS1040
10	5/8	60	PS1060
216mm	5/8	24	PS2165/824
216mm	30mm	48	PS2163048
216mm	30mm	60	PS2163060
10	30mm	80	PS103080

